

# AGV Task Challenge

## Competition Brief

2023.0511

### A. Origins of the Project :

ShaYangYe is committed to the advancement of robot education and the promotion of industry collaboration, aiming to establish Taiwan as an international stage for robotics competitions. Since 2018, we have jointly organized the INTERNATIONAL ROBOTIC FESTIVAL IN TAOYUAN with the Taoyuan City Government for five consecutive years. This groundbreaking event brings together the four major fields of land, sea, air, and makers in robotics competitions. Over the past five years, we have achieved remarkable records with over 10 million participants both online and offline, teams from 20 countries competing together, and a total of 8,200 teams participating from domestic and international sources. Our goal is to promote related industries through robot training and competitions, expand the international perspectives of Taiwanese participants, and create a cross-domain international robotics event that shines in Taoyuan and the world! In the 2023 INTERNATIONAL ROBOTIC FESTIVAL IN TAOYUAN, in order to further promote Taiwan's robot industry and self-made brands, we have planned a series of competitions, starting with the TIRT-AGV Mission Challenge. This competition combines various control systems to showcase Taiwan's technological prowess in smart manufacturing and serves as a connection to the TIRT International Competition and Conference!

### B. Objectives of the Project :

1. We aim to increase opportunities for domestic and international teams to observe programming, mechatronics integration, and share and exchange ideas through competitions and workshops. By doing so, we hope to inspire students to learn and become more motivated.
2. We plan to integrate diverse open control systems and design different competition objectives that combine and expand students' abilities in creativity, design, integration, and programming.

### C. Guiding Organization :

Taoyuan City Government · Taoyuan City Council

### D. Host Organization :

Department of Economic Development, Taoyuan

### E. Executing Unit :

SHAYANGYE Cultural & Educational Foundation

## **F. Eligible Participants :**

1. Students from all primary, junior high, senior high schools, vocational schools, and colleges and universities across the country (including master's and doctoral students)
2. Participants must have a valid student status recognized by the Ministry of Education.
3. International teams of the same age group are allowed to participate (must provide proof of valid student status in their respective countries).

## **G. Competition events :**



## **H. Competition grouping :**

1. High School Category: Limited to high school students, with a maximum of 3 team members per team.
2. College/University Category: Limited to college/university students (including master's and doctoral students), with a maximum of 3 team members per team.

## **I. Event description and schedule planning :**

1. Registration method : Go to the TIRT official website (<https://www.tirtpointsrace.org/>) click 「 」 to proceed with registration.
2. registration period : June 31, 2023 to October 15, 2023(It may be subject to adjustment according to the registration status of the teams.)
3. Competition schedule: October 28th, 2023.
4. Competition location : The Taoyuan Arena(No. 1, Section 1, Sanmin Road, Taoyuan District, Taoyuan City.)

## **J. Other matters:**

The organizer reserves the right to modify the regulations and rules of the competition; for any unmentioned matters, the latest announcement from the organizer on the official competition website shall prevail. If you have any questions or concerns, please contact Mr. Chin at 03-3623452 ext. 5338, the organizer's contact number.

# AGV Task Challenge

## Competition Rules

2023.0518版

### A. Competition grouping :

1. High School Category: Limited to high school students, with a maximum of 3 team members per team.
2. College/University Category: Limited to college/university students (including master's and doctoral students), with a maximum of 3 team members per team.

### B. Machine Specifications for Competition :

1. The machine must be designed to carry the battery on-board as a power source.
2. The retracted dimensions of the vehicle's extension mechanism should not exceed 45 cm in length, 40 cm in width, and 20 cm in height.
3. The machine must be equipped with a device capable of transporting a movable rack, such as a lifting mechanism or a towing mechanism.
4. The tasks must be completed autonomously, and instructions for the tasks may be issued through devices such as computers. Remote control is strictly prohibited throughout the entire duration of the tasks °

### C. Competition Venue Introduction :

1. The dimensions of the field are 700 cm in length and 400 cm in width.
2. The field has a black background with white lines. The width of the white lines is 2.5 cm.

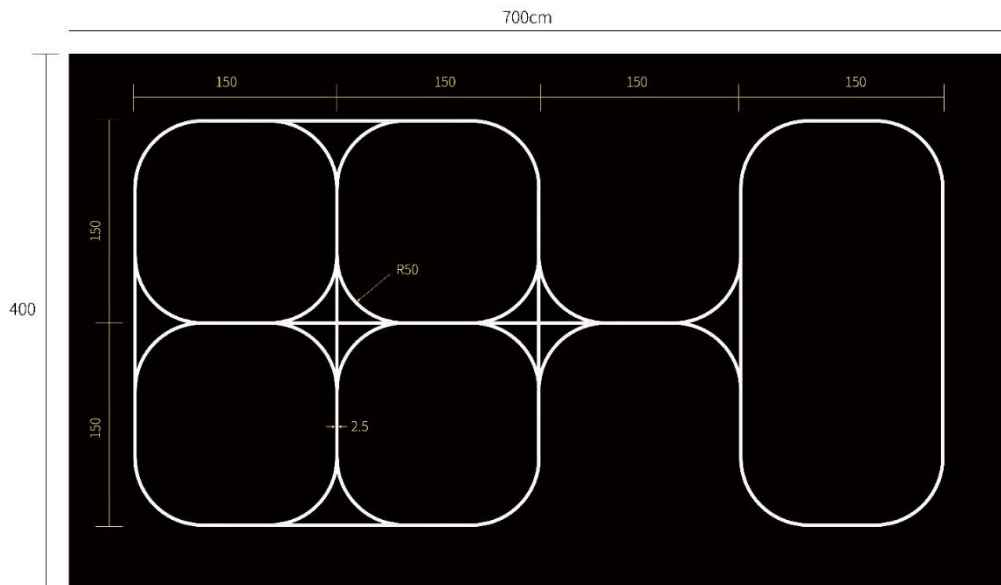

## D. Competition Rules and Regulations :

1. All participants must complete the registration and check-in process. The competition order will be determined through a random drawing. Participants will wait on the sidelines in the order determined by the drawing. Once the machine has undergone the check-in process, it must be placed in a designated area specified by the organizers. Participants are not allowed to retrieve the machine or make any adjustments to the microprocessor chip (program) during the competition.
2. Competition Order: According to the instructions of the relevant referees and staff, participating teams will enter the competition venue in a specified order. At any given time, only one team will be competing on a specific field.
3. Machines that do not pass the check-in process are not allowed to participate in the competition.
4. Each team has a competition time of 15 minutes per match and can complete up to 3 rounds of task challenges. The scores and completion times for each round are calculated, and the round with the highest score is considered the best performance. During this period, participants are allowed to place their own sensor markers (must bring their own sensor markers) and make hardware and programming adjustments to their vehicles. The competition time will be adjusted based on the number of teams present at the venue.
5. Participants are required to place sensor markers that can be easily removed without leaving any residue. It is strictly prohibited to cause any damage to the competition venue. If a participant is found to have caused damage to the venue, the referee has the authority to disqualify them from the competition.
6. Before each round begins, participants are required to signal to the referee (by raising hand) that they are ready. The referee will then start the timer. Participants can activate their machines and proceed with the task challenges. Once all the tasks are completed, participants must signal to the referee (by raising hand) that they have finished all the tasks. The referee will then stop the timer and calculate the scores and completion time for that round's tasks.
7. Before each round starts, participants are allowed to make adjustments to their machines and program settings. However, once the round begins and the timer starts, participants are not allowed to touch the machine again. They can use devices such as computers to issue task commands but are prohibited from using remote control throughout the entire duration of the tasks.

8. If a machine experiences a malfunction during a round, participants should signal to the referee (by raising hand) to indicate the end of that round. The referee will then calculate the scores based on the tasks that have been completed up until that point.
9. During the competition, any adjustments made to the machine must comply with the specifications outlined in the machine regulations. After making adjustments, the machine should still adhere to the rules and requirements set for participating machines.
10. The machine must stay within the white lines throughout the entire competition. If the machine deviates from the white lines, the current round will be ended, and the scores will be calculated based on the tasks completed up until that point.
11. The competition rankings will be determined based on the scores earned. Participants with higher scores will be ranked higher. In the event of a tie in scores, the rankings will be determined based on the competition time, with the participant who completed the tasks in a shorter time being ranked higher and declared the winner.
12. The referee has the final authority in making decisions regarding the competition. Participants are not allowed to dispute or challenge the decisions made by the referee. The referee's decisions are considered final and binding.
13. In the event of any unforeseen circumstances or situations that cannot be adequately addressed by the existing rules and regulations, the organizing committee has the authority to interpret and make decisions. The final decision rests with the head referee, and participants are not allowed to dispute or challenge their rulings. The organizing committee's interpretation and decisions in such cases are considered final.
14. The competition venue strictly prohibits any form of damage or contamination. If a participant is found to have caused significant damage or contamination to the competition venue, they may lose their eligibility to participate in the competition. It is important for participants to respect and preserve the integrity of the competition venue throughout the event. °

## E. Competition tasks for the high school and vocational school category. :

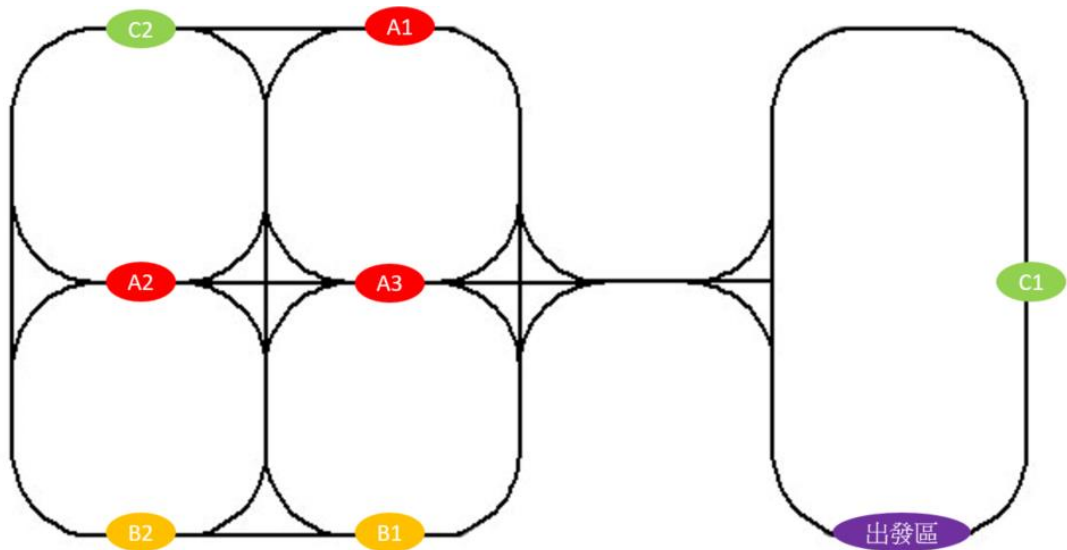

1. Each team is required to prepare an unmanned transport vehicle to perform the tasks. The tasks will begin from the starting area, and there are a total of three tasks to be executed (the order of task execution is not restricted) :
  - Task A** : The vehicle moves to A1 to retrieve a shelf. Then, the vehicle moves the shelf to A2, where the side roller releases the cargo. The player manually activates the roller to drop the cargo onto the shelf. Finally, the vehicle places the shelf in the designated A3 area.
  - Task B** : The vehicle moves to B1 to retrieve a shelf. Then, the vehicle moves the shelf to B2 for precise placement. Above the B2 area, there will be laser points illuminating circular targets on the shelf.
  - Task C** : The vehicle moves to C1 to retrieve a shelf. On the shelf, there will be 8 cans of 600ml bottled water placed above it. Then, the vehicle smoothly moves the shelf to the C2 area, and the scoring will be based on the condition of the loaded items.
2. When all three tasks are completed, the player needs to signal to the referee by raising their hand to indicate that all tasks have been completed. The referee will then stop the timing for that round.
3. The block colors are used for illustrative purposes only and do not represent the actual field. The boundaries of the areas will be determined by straight line segments instead of colored blocks.



## F. Tasks for College/University Professional Division Competition :

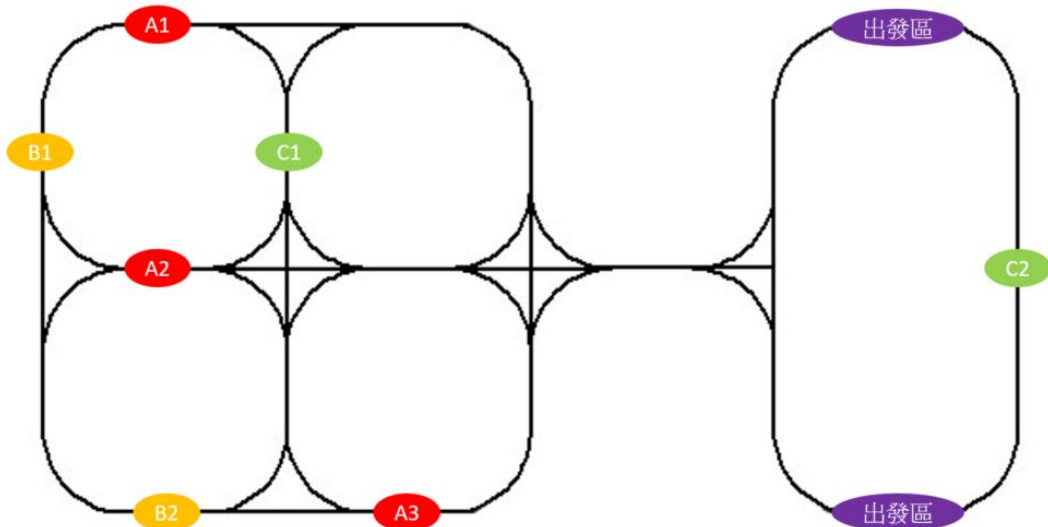

1. Each team needs to prepare two unmanned transport vehicles to perform tasks, starting from the departure zone. There are three tasks to be executed (the order of task execution is not restricted) :

**Task A** : The vehicle should move to position A1 and retrieve a shelf. Then, the vehicle must transport the shelf to position A2 where the side roller will release a cargo item. The participant needs to manually activate the roller to release the cargo onto the shelf. Finally, the vehicle should move the shelf to the designated area at position A3.

**Task B** : The vehicle should move to B1 to retrieve a shelf and then transport the shelf to B2 for accurate placement. Above the B2 area, there will be laser points illuminating circular targets on the shelf.

**Task C** : The vehicle moves to C1 to retrieve a shelf. On top of the shelf, there are 8 cans of 600ml bottled water. The vehicle then smoothly transports the shelf to the C2 area, and scoring is based on the condition of the loaded items.

2. Both vehicles must jointly perform the task. If it is found by the referee that only one vehicle has performed the task, it will result in disqualification (zero points for that round of the task). °
3. When all three tasks are completed, the participant must signal to the referee (by raising their hand) that they have completed all the tasks, and the referee will stop the timing for that round.
4. The colored blocks are for illustrative purposes only and do not exist on the actual track. The boundaries of the sections are determined by the straight line segments.

## G. Scoring Method :

1. Task A : Receive goods on the shelf without any items falling off (30 points), then move the shelf to the designated area and place it there (20 points).
2. Task B : Score points based on the position of the laser pointer on the circular target. The score ranges from 1 to 10 points. If the position is on the boundary line between 9 and 8 points, it will be considered as 9 points, the closest to the higher score.
3. Task C : Move the shelf to position C2 and score points based on the number of bottled water remaining on the shelf. Each bottle is worth 5 points, with a maximum of 40 points.
4. Competition scoring is calculated as follows: First, ranking is determined by the score obtained. Participants with higher scores are ranked higher. In case of a tie, the ranking is then based on the competition time, with the shorter time resulting in a higher ranking. °

## H. Scoring Sheet :

Team number :			
Best lap time	Total		
	finish time		
Round 1			
Mission	Task A	Task B	Task C
Score			
Total			
finish time			
Round 2			
Mission	Task A		Task B
Score			
Total			
finish time			
Round 3			
Mission	Task A		Task B
Score			
Total			
finish time			



## I. Specifications for Race Equipment :

1. Shelf : The main structure is made of 30mmX30mm extruded aluminum.

Shelf Dimensions : (Length) 500mm X (Width) 500mm X (Height) 800mm (as shown in Figure 1).

Shelf Weight : 11.56kg.

Shelf Base Plate Dimensions : 500mmX500mm aluminum plate with 2 holes drilled (as shown in Figure 2).

Shelf Base Plate Height from the ground : 180mm.

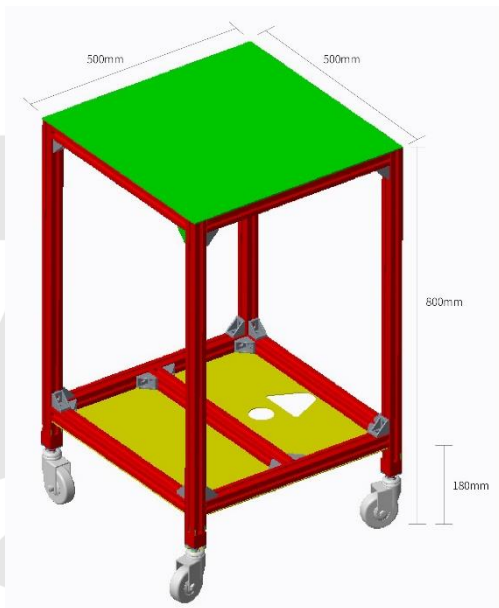

Figure 1: Shelf (Unit: mm)

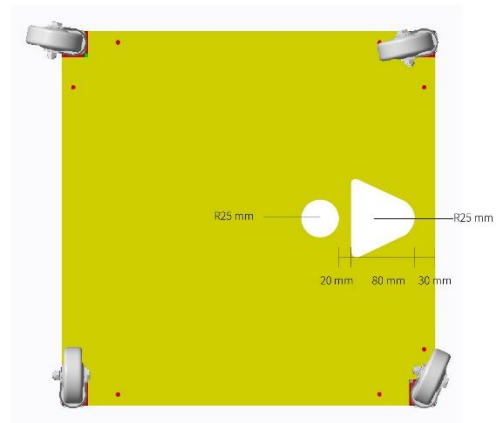

Figure 2: Shelf Base (Unit: mm)

2. Roller: The main structure is made of 30mmX30mm extruded aluminum, with roller dimensions as shown in Figure 3.

The distance between the roller and the white line is 240mm, as shown in Figure 4.) °



Figure 3: Roller Coaster  
(Unit: mm)

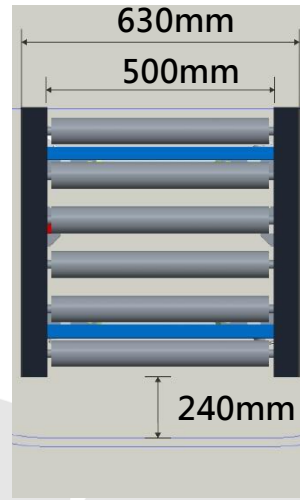

Figure 4: Roller Coaster  
(Unit: mm)

3. Item : Dimensions of the item are (length) 390mm X (width) 200mm X (height) 195mm (as shown in Figure 1).

Item Weight : 372g

Material of the item : Cardboard.

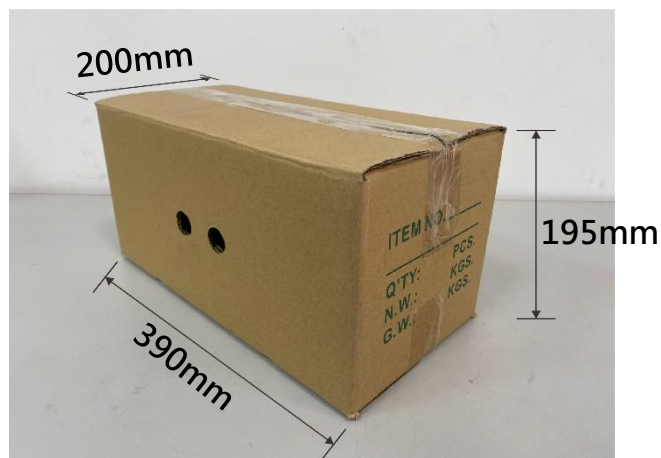

Figure 5: Cargo (unit: mm).

4. Laser Point Rack Dimensions (as shown in Figures 6 and 7) :



Diagram 6: Laser Point Bracket (Unit: mm)

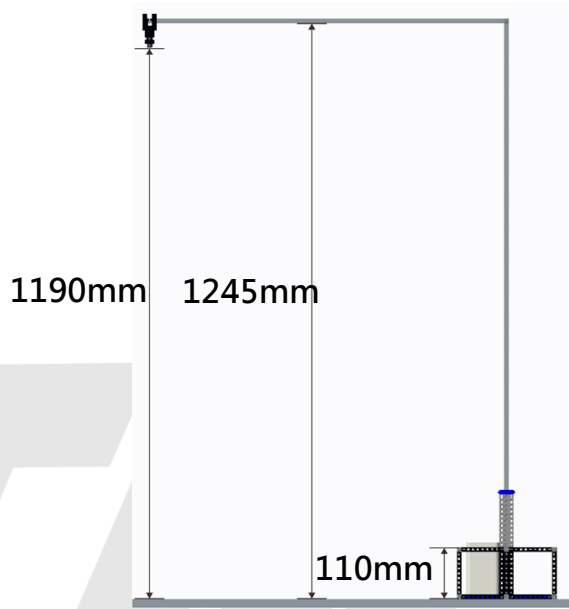

Diagram 7: Laser Point Bracket (Unit: mm)

5. Circular Target: Scoring 10 points for hitting the center with a radius of 1cm. For every subsequent 1cm increase in radius, the score decreases by 1 (as shown in Figure 8).

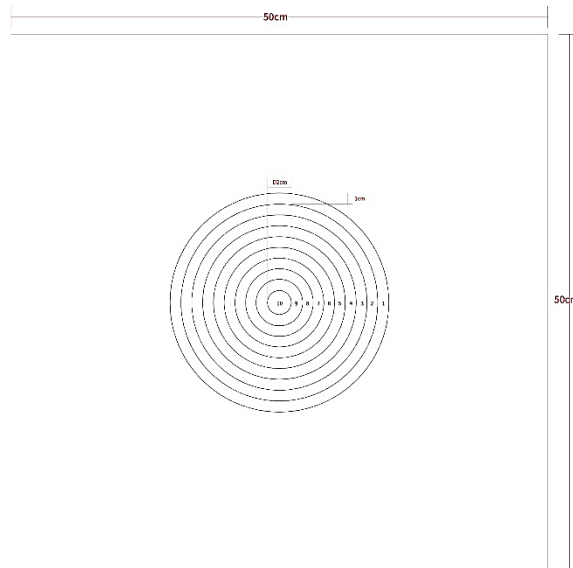

Figure 8 Circular Target (unit: cm)

6. Bottled Water (600ml): Dimensions 240mm in height X 64.3mm in width (as shown in Figure 9), weight: 624g.

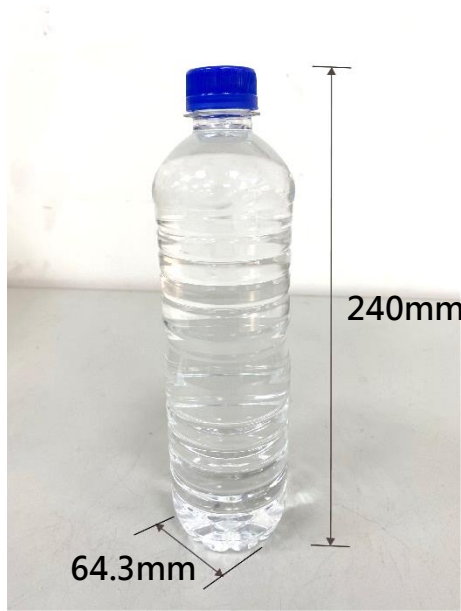



Diagram 9 : bottles of water (unit: mm)

7. The competition-related props shall adhere to the specifications set at the venue and shall not be disputed.

**TIRT**  
**2023 AI TAOYUAN**

## J. Reward Mechanism :

### 1. High School and Vocational Group :

Ranking	Bonus (NTD)	Certificate
 <b>1<sup>st</sup> Prize</b>	<b>\$5,000</b>	<b>V</b>
 <b>2<sup>nd</sup> Prize</b>	<b>\$3,000</b>	<b>V</b>
 <b>3<sup>rd</sup> Prize</b>	<b>\$2,000</b>	<b>V</b>
 <b>Excellent Work</b>	<b>-</b>	<b>V</b>

### 2. College and University Group :

Ranking	Bonus (NTD)	Certificate
 <b>1<sup>st</sup> Prize</b>	<b>\$12,000</b>	<b>V</b>
 <b>2<sup>nd</sup> Prize</b>	<b>\$8,000</b>	<b>V</b>
 <b>3<sup>rd</sup> Prize</b>	<b>\$5,000</b>	<b>V</b>
 <b>Excellent Work</b>	<b>-</b>	<b>V</b>

K. For any other matters not covered, the organizing committee will make decisions based on the on-site conditions.